

# SAFETY

Glassware for  
Your Lab



**SAFETY**  
**1<sup>st</sup>**

**waiser**  
scientific

Distribuidor Oficial

**KIMBLE CHASE**

**WAISER Científica Ltda.**

Tel: 11 2958 0700

info@waiser.com.br

www.waiser.com.br



## Choose KimCote® Plastic-Coated Glassware for an Added Measure of Safety!

### Features & Benefits

Plastic coating on glassware	→ Prevents & contains spills in broken glassware
Ultra-clear coating	→ Improved sample viewing
Non-slip coating surface	→ Easier handling in the lab
Steam autoclavable	→ Easy to clean and sterilize
Chemical resistant	→ For use with hazardous chemicals
Odor free coating	→ No noxious fumes present

KimCote protective glassware coating goes beyond traditional coatings. Should a break occur, KimCote will reduce the hazards of shattered glass and leakage of toxic or corrosive chemicals. It's ultra-clear, extremely durable, autoclavable and resistant to many common laboratory chemicals. KimCote's unique texture also provides a non-slip handling surface, wet or dry.

### Use KimCote anywhere you want to increase safety!

- Pressurized glassware
- Chemical storage
- Transportation of samples
- Handling of hazardous chemicals, harmful biologicals and acids

### Estamos aqui para ajudar.

Se você não encontrar o que precisa, ligue para nós. Nosso grupo de atendimento ao cliente ficará feliz em discutir suas necessidades especiais.

**Central de atendimento WAISER: 11 2958-9500**

### Table of Contents

#### KimCote® Plastic-Coated Glassware

Bottles .....	1-3
Cylinders .....	4
Flasks (Coated and Uncoated) .....	4-6
Funnels .....	6
Tissue Grinders .....	7
Tubes .....	8

#### Other Safety Products

Heavy-Duty Beakers .....	8
Color-Coded Glassware .....	9
Heavy-Duty Volumetric Flasks .....	10-11
HPLC Accessories .....	12-16

Care and Handling of Glassware .. 17-20

Catalog Number Index .....

Distribuidor Oficial



*Your Source for Kimble, Kontes and Chase Brands*



**WAISER Científica Ltda.**

Tel: 11 2958 0700  
info@waiser.com.br

[www.waiser.com.br](http://www.waiser.com.br)

### Atmospheric Environmental Bottles

- KimCote® plastic safety coating
- Borosilicate glass high vacuum plug valve stems eliminate outgassing.
- Viton® valve stem o-rings standard, other materials available
- Inlet stems ground to 1/2" O.D. for use with ULTRA-TORR® or CAJON® fittings.

The design of our Atmospheric Environmental Bottle is recommended by the Atmospheric Environment Service (AES). Available in either a single or a double valve configuration.

Catalog Number	Description	Approx. Capacity (mL)	O-Ring Size Shaft-Tip	Approx. Overall Height x Width (mm)	Case Qty.
653200-2000	Single Valve Model	2000	110-108	345 x 100	1
653210-2000	Double Valve Model	2000	110-108	345 x 135	1

### Reservoir Bottles with Bottom Hose Outlet

- KimCote® plastic safety coating
- Bottom hose outlet
- Tooled top and narrow mouth
- White enamel marking spot
- Glass conforms to ASTM E438, Type I, Class A

KIMAX glass hose connection outlet is fused to the bottle. Sizes 250 and 500 mL accept 5/16" I.D. flexible tubing, 1000 mL and larger accept 3/8" I.D. tubing. White enamel marking spot.

Catalog Number	Approx. Capacity (liters)	Approx. Neck ID at Top (mm)	Rubber Stopper Size	Approx. Dia. (mm)	Approx. Height (mm)	Case Qty.
KC14607-250	250 mL	18	2	72	132	6
KC14607-500	500 mL	22	4	89	165	6
KC14607-1000	1 L	27	6	110	200	4
KC14607-2000	2 L	27	6	136	250	4
KC14607-5000	5 L	42	10	183	320	1
KC14607-10000	10 L	58	11.5	230	400	1
KC14607-20000	20 L	58	11.5	290	495	1

### Heavy-Duty Serum Bottles

- KimCote® plastic safety coating
- Uses #8 rubber stopper
- Glass conforms to ASTM E438, Type I, Class A

KIMAX bottle with rounded shoulders. Neck is tooled for a uniform fit with a #8 rubber stopper.

Catalog Number	Approx. Capacity Liters - Gallons	Approx. Dia. (mm)	Approx. Height (mm)	Case Qty.
KC14960-4	4 - 1	167	310	1
KC14960-9	9 - 2	203	412	1

All the glassware on this page is plastic-coated for added safety.



653200



653210



KC14607



KC14960

All the glassware on this page is plastic-coated for added safety.



KC14950



Accessory Clamp and Stopper Assembly



KC15093



KC15097

## KIMAX® Heavy-Duty Solution Bottle (Carboy)

- KimCote® plastic safety coating
- Neck is tooled for a #12 stopper
- 5 gallon size is designed from Federal Specification DD-B-597

Catalog Number	Approx. Capacity Liters - Gallons	Approx. Dia. (mm)	Approx. Height (mm)	Case Qty.
KC14950-25	9.5 - 2.5	222	392	1
KC14950-35	13.2 - 3.5	257	448	1
KC14950-500	19.0 - 5.0	294	502	1
KC14950-120	45.5 - 12.0	410	584	1

### Carboy Clamp and Silicone Stopper Assemblies for KC14950 Solution Bottles

- Two or Three-port, platinum cured stopper assembly
- Sanitary KYNAR® clamp for sterile transfer with no extractables
- Ports connect to 1/8", 1/4" (4-port stopper has two 1/4" tubes) and 3/8" with 2' silicone tubing at both ends

Catalog Number	Description	Tubing Connections	Case Qty.
14950C-12	Clamp	-	1
14950S-321	Stopper, 3-port	1/8"(1) 1/4"(1) 3/8"(1)	1
14950S-2321	Stopper, 4-port	1/8"(1) 1/4"(2) 3/8"(1)	1

KYNAR is a registered trademark of ARKEMA for polyvinylidene fluoride.

## KIMAX® Narrow Mouth Solution Bottles for use with Rubber Stoppers

- KimCote® plastic safety coating
- Conforms to ASTM E438, Type 1, Class A glass
- Uses #11.5 stopper

Catalog Number	Approx. Cap. (L)	Approx. Neck I.D. at Top (mm)	Rubber Stopper Size	Approx. Dia. (mm)	Approx. Height (mm)	Case Qty.
KC15093-10000	10	58	11.5	230	400	1
KC15093-20000	20	58	11.5	290	495	1

## KIMAX® Narrow Mouth Solution Bottles with Color-Coded PTFE ⌘ Flathead Stoppers

- KimCote® plastic safety coating
- Conforms to ASTM E438, Type 1, Class A glass
- Necks are ⌘ ground for stoppers
- Color-coded stoppers included

Catalog Number	Approx. Cap. (mL)	Approx. Dia. (mm)	Approx. Height with Stopper (mm)	Stopper ⌘ Size	Stopper Color	Case Qty.
KC15097-100	100	53	110	14	Red	12
KC15097-250	250	72	145	19	Grey	6
KC15097-500	500	89	180	24	Blue	6
KC15097-1000	1000	110	215	29	Green	6
KC15097-2000	2000	136	265	29	Green	1

## KIMAX® Storage / Media Bottles with Linerless Blue Polypropylene Cap

- KimCote® plastic safety coating
- GL 45 screw thread bottles have white graduations and marking spots
- Wide opening for easy access (approx. 30 mm ID)
- Polypropylene cap is steam autoclavable (140°C max)
- Replaceable pour ring included

Catalog Number	Approx. Capacity (mL)	Graduations Range (mL)	Interval (mL)	Approx. OD (mm)	Approx. Height (mm)	Case Qty.
KC14395-100	100	20-80	10	56	100	4
KC14395-250	250	50-200	25	70	138	4
KC14395-500	500	100-400	50	86	176	4
KC14395-1000	1000	100-900	50	101	225	4
KC14395-2000	2000	400-1800	100	136	262	4
KC14395-5000	5000	1000-4000	250	186	355	1
KC14395-10000	10000	2000-8000	500	234	435	1

### Replacement Caps and Pour Rings

14395C-45	Blue Cap	10
14395P-45	Clear Pour Ring	10

## GL 45 Screw Thread Caps for Media Bottles

- Solid top polypropylene GL 45 caps with internal molded sealing rings

Catalog Number	Description	Maximum Temperature	Case Qty.
14395C-45	Blue Cap	140°C	10
14395C-451	White Cap	140°C	10
14395C-453	Orange Cap	140°C	10

## GL 45 Screw Thread Caps with Membranes

- Open top cap has a 0.2 micron PTFE membrane sealed in
- Membrane functions as a barrier to allow pressure equalization during low temperature autoclaving (140°C max)

Catalog Number	Description	Maximum Temperature	Case Qty.
14395M-45	Blue Cap with 0.2µ Membrane	140°C	10

## GL 45 Screw Thread PBT Caps (High Temperature)

- For use up to 180° C
- PBT (Polybutyleneterephthalate) cap material with PTFE-faced silicone liner
- Excellent chemical resistance to alcohols, ethers, hydrocarbons, and strong acids

Catalog Number	Description	Maximum Temperature	Case Qty.
14395H-452	High Temp Cap, Red	180°C	10

## Pour Rings for KIMAX® GL 45 Storage / Media Bottles

- Clear polypropylene or red ETFE for high temperatures

Catalog Number	Description	Maximum Temperature	Case Qty.
14395P-45	Polypropylene, Clear	140° C	10
14395E-452	ETFE, Red, High Temperature	180° C	10

All the glassware on this page is plastic-coated for added safety.



KC14395



14395C



14395M



14395H



14395P



**KIMAX® Class A Graduated Cylinders with Bumpers**

- KimCote® plastic safety coating
- Calibrated "To Deliver" - TD
- Reverse metric scale
- Ground base for stability

All the glassware on this page is plastic-coated for added safety.



KC20028W

Catalog Number	Cap. (mL)	Grad. Interval (mL)	Subdiv. (mL)	±Tol. (mL)	Approx. Height (mm)	Bumper Size	Case Qty.
KC20028W-100	100	5 to 100	1	0.40	255	4	1
KC20028W-250	250	10 to 250	2	0.80	330	6	1
KC20028W-500	500	25 to 500	5	1.30	375	7	1
KC20028W-1000	1000	50 to 1000	10	2.50	460	8	1
KC20028W-2000	2000	100 to 2000	20	6.00	520	9	1

**Use KimCote® plastic-coated glassware anywhere you want to increase safety!**

KimCote protective glassware coating goes beyond traditional coatings. Should a break occur, KimCote will reduce the hazards of shattered glass and leakage of toxic or corrosive chemicals. It's ultra-clear, extremely durable, autoclavable and resistant to many common laboratory chemicals. KimCote's unique texture also provides a non-slip handling surface, wet or dry.

- Pressurized glassware
- Chemical storage
- Transportation of samples
- Handling of hazardous chemicals, harmful biologicals and acids



KC26720

**KIMAX® Erlenmeyer Flasks with GL 45 Screw Caps**

- KimCote® plastic safety coating
- Large openings and GL 45 threaded closures for easy access and tight sealing
- Blue caps and clear pour rings included
- Marking spots and scales are durable white ceramic enamel

Catalog Number	Capacity (mL)	Approx. Widest Dia. (mm)	Approx. Height with Cap (mm)	Case Qty.
KC26720-250	250	81	130	6
KC26720-500	500	102	165	6
KC26720-1000	1000	128	205	4
KC26720-2000	2000	161	265	2



**KimCote® can help prevent & contain spills in broken glassware until safe disposal can be made.**

## ULTRA-WARE® Heavy-Wall Filter Flasks

- KimCote® plastic safety coating
- Heavy-wall borosilicate glass provides mechanical strength for vacuum filtration
- #2 side arm for connection to 1/4" (6 mm) I.D. flexible tubing

Catalog Number	Cap. (mL)	Rubber Stopper Size	Hose Connection	Case Qty.
953760-0122	125	5	#2	1
953760-1002	1000	8	#2	1
953760-2002	2000	8	#2	1
953760-4002	4000	8	#2	1

## KIMAX® Heavy-Wall Filter Flasks with Graduations

- Designed to hold 1 atmosphere of vacuum or 29" of mercury
- Sizes 25 - 500 mL have hose connections for 5/16 inch I.D. flexible tubing
- Sizes 1000 - 4000 mL have hose connections for 3/8 inch I.D. flexible tubing
- Designed from ASTM Specification E1406, Type II, Class I requirements

Catalog Number	Cap. (mL)	Graduated Interval (mL)	Subdiv. (mL)	Rubber Stopper Size	Approx. Widest Dia. (mm)	Approx. Height (mm)	Shelf-Pack Qty.	Case Qty.
27060-25	25	5 to 25	5	3	40	74	6	18
27060-50	50	20 to 50	10	4	48	81	6	18
27060-125	125	50 to 125	25	5	69	111	6	18
27060-250	250	50 to 250	25	6	83	163	6	18
27060-500	500	150 to 500	50	7	104	190	6	18
27060-1000	1000	300 to 1000	50	8	135	238	6	12
27060-2000	2000	600 to 2000	100	9	168	300	—	1
27060-4000	4000	1000 to 4000	250	12	208	380	—	1

## KIMAX® Heavy-Wall Filter Flasks with Graduations and Detachable Plastic Sidearms

- Sidearm designed for 5/16 inch I.D. flexible tubing (U.S. Patent 3,268,300)
- Finger grips on sidearm provide easy insertion into neoprene grommet on flask
- Designed from ASTM Specification E1406, Type III, Class 2 requirements

Catalog Number	Cap. (mL)	Graduated Interval (mL)	Subdiv. (mL)	Rubber Stopper Size	Approx. Widest Dia. (mm)	Approx. Height (mm)	Shelf-Pack Qty.	Case Qty.
27065-250	250	50 to 250	25	6	83	163	2	18
27065-500	500	150 to 500	50	7	104	190	2	18
27065-1000	1000	300 to 1000	50	8	135	238	2	12
27065-2000	2000	600 to 2000	200	9	168	300	—	1
27065-4000	4000	1000 to 4000	250	12	208	380	—	1

## KIMAX® Heavy-Wall Filter Flasks with Graduations and Quick-Release Hose Barb Connectors

- Threaded sidearm and quick-release connector allow for permanent connection of 1/4 inch I.D. flexible tubing to the connector
- Designed to hold 1 atmosphere of vacuum or 29" of mercury
- Designed from ASTM Specification E1406, Type II, Class 2 requirements

Catalog Number	Cap. (mL)	Graduated Interval (mL)	Subdiv. (mL)	Rubber Stopper Size	Approx. Widest Dia. (mm)	Approx. Height (mm)	Shelf-Pack Qty.	Case Qty.
27070-250	250	50 to 250	25	6	83	163	—	2
27070-500	500	150 to 500	50	7	104	190	2	8
27070-1000	1000	300 to 1000	50	8	135	238	—	1
27070-2000	2000	600 to 2000	100	9	168	300	—	1
27070-4000	4000	1000 to 4000	250	12	208	380	—	1



953760



27060



27065



27070

All the glassware on this page is plastic-coated for added safety.



KC25330



KC25165



KC28014



KC29048T

### Heavy Wall Round Bottom Boiling Flasks with 35/25 Joints

- KimCote® plastic safety coating
- Ideal as a collection flask with rotary evaporators from all major manufacturers
- Joint size may be used as a replacement for European designation KS 20/35

Catalog Number	Capacity (mL)	35/25 Joint	Approx. Dia. (mm)	Case Qty.
KC25330-100	100	35/20	60	1
KC25330-250	250	35/25	83	1
KC25330-500	500	35/25	102	1
KC25330-1000	1000	35/25	130	1
KC25330-2000	2000	35/25	161	1

### Heavy Wall Recovery Flask with Square 24/40 Joint Bead

- KimCote® plastic safety coating
- Ideal as a recovery flask with rotary evaporators from all major manufacturers
- Lower portion fits standard heating mantles

Catalog Number	Capacity (mL)	24/40 Joint	Case Qty.
KC25165-50	50	24/40	1
KC25165-100	100	24/40	1
KC25165-200	200	24/40	1
KC25165-500	500	24/40	1
KC25165-1000	1000	24/40	1

### KIMAX® Volumetric Flask with 24/40 Glass Stopper, Class A

- KimCote® plastic safety coating
- Single graduation ring is calibrated "To Contain" - TC
- Designed from ASTM Specification E288, Class A unserialized requirements
- Marking spots are durable white ceramic enamel
- Replacement stopper is 41900R

Catalog Number	Capacity (mL)	±Tol. (mL)	24/40 Stopper	Approx. Height with Stopper (mm)	Case Qty.
KC28014-100	100	0.08	13	180	12
KC28014-250	250	0.12	16	250	12
KC28014-500	500	0.20	19	287	12
KC28014-1000	1000	0.30	22	338	4
KC28014-2000	2000	0.50	27	400	2

### KIMAX® Pear-Shaped Separatory Funnel with 24/40 Glass Stopper and Autoclavable PTFE Stopcock Plug

- KimCote® plastic safety coating
- Lower stems have an I.D. large enough so that a column of liquid will "break" with the stopcock closed, thereby giving a more complete separation and eliminating the necessity of emptying the funnel.
- Designed from ASTM Specification E1096, Type 4 requirements

Catalog Number	Capacity (mL)	24/40 Stopcock Size	24/40 Stopper	Length of Stem (mm)	Case Qty.
KC29048T-125	125	2	22	60	4
KC29048T-250	250	4	22	60	4
KC29048T-500	500	4	27	60	4
KC29048T-1000	1000	4	27	60	1
KC29048T-2000	2000	6	38	60	1



**DUALL® Tissue Grinder, All-Glass, with KimCote® Plastic Coated Tube**

- KimCote® plastic safety coating
- Plastic coating on tube will help contain the homogenate if the tube breaks or cracks during motor driven homogenization
- Replacement components are available and completely interchangeable
- Clearance between pestles and tubes is 0.004” to 0.006”

Catalog Number	Size	Working Cap. (mL)	Pestle Overall x Shaft O.D. (mm)	Tube Overall x Res. O.D. (mm)	Case Qty.
885460-0020	20	1	155 x 6	80 x 13	1
885460-0021	21	3	207 x 6	120 x 16	1
885460-0022	22	5	220 x 8	150 x 18	1
885460-0023	23	15	278 x 10	175 x 25	1
885460-0024	24	30	310 x 10	215 x 32	1
885460-0025	25	50	345 x 16	225 x 38	1

Pestles Only			Tubes Only		
Catalog No.	Description	Case Qty.	Catalog No.	Description	Case Qty.
885451-0020	Pestle, Size 20	1	885462-0020	Tube, Size 20	1
885451-0021	Pestle, Size 21	1	885462-0021	Tube, Size 21	1
885451-0022	Pestle, Size 22	1	885462-0022	Tube, Size 22	1
885451-0023	Pestle, Size 23	1	885462-0023	Tube, Size 23	1
885451-0024	Pestle, Size 24	1	885462-0024	Tube, Size 24	1
885451-0025	Pestle, Size 25	1	885462-0025	Tube, Size 25	1



**Closed System, Sterile Tissue Grinders for Maximum User Safety and Convenience**

- Grinding occurs within a closed system for your protection
- Exposure to sample aerosols is eliminated
- Narrow pestles eliminate sample overflow
- Convenient and easy-to-use
- CS1 for standard grinding and CS2 for more aggressive grinding

**CS1 and CS2 Sterile Tissue Grinders** are easy to use and designed for your safety. The molded-in abrasive surface on the CS1 pestle tip leaves no sediment to obstruct sample examination. CS2 grinders have vitrified tips for more aggressive grinding of tougher tissues. Each grinder comes with a fully assembled pestle, a conical sample tube with solid top cap, an adhesive identification label and an instruction card. All are gamma sterilized in easy-open Tyvek® packs. Tubes are made of PP, pestles are 30% glass-filled PP and caps are HDPE.

**For standard grinding.**

Catalog Number	Description	Capacity (mL)	Case Qty.
749600-0015	CS1 with Molded Tip	15	10
749600-0050	CS1 with Molded Tip	50	10

**For more aggressive grinding.**

Catalog Number	Description	Capacity (mL)	Case Qty.
749610-0015	CS2 with Vitrified Tip	15	10
749610-0050	CS2 with Vitrified Tip	50	10

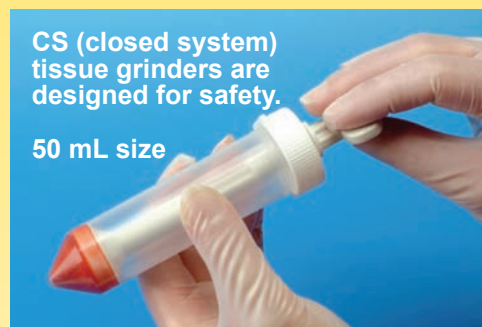

## KIMAX® Screw Thread Culture Tubes with Unattached Rubber-Lined Caps

- KimCote® plastic safety coating
- Made from KG-33 borosilicate glass for maximum heat transfer and excellent chemical resistance
- Ideal for biohazard test protocols
- Uniform wall thickness for increased resistance to mechanical shock
- Thread finish complies with Glass Packaging Institute (GPI) requirements
- Designed from ASTM E982, Type VI, Class A requirements



Cap shown attached but tubes are supplied with caps unattached.

KC45066



45066B  
45066C

Catalog Number	Approx. O.D. and Length (mm)	Capacity to Neck (mL)	GPI Thread Finish	Case Qty.
KC45066-13100	13 x 100	8	13-415	144
KC45066-16125	16 x 125	16	15-415	144
KC45066-20150	20 x 150	30	18-415	96
KC45066-25150	25 x 150	50	24-410	48

### Phenolic Caps with White Rubber Liners

Catalog Number	Thread Size	Approx. Cap Height (mm)	Case Qty.
45066B-13	13-415	14	300
45066B-15	15-415	16	300
45066B-18	18-415	18	225
45066B-24	24-410	19	150

### Phenolic Caps with PTFE-Faced Rubber Liners

Catalog Number	Thread Size	Approx. Cap Height (mm)	Case Qty.
45066C-13	13-415	14	300
45066C-15	15-415	16	300
45066C-18	18-415	18	225
45066C-24	24-410	19	150

Thick, uniform walls for increased resistance to mechanical shock.

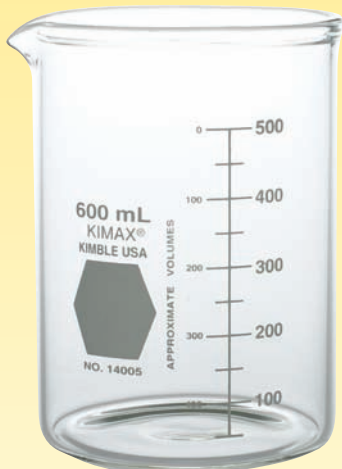

14005

## KIMAX® Heavy-Duty Low Form Beakers with Double Capacity Scales

- Made from heavy wall tubing for more even and uniform wall thickness
- Uniformity of construction allows for use on hot plates
- Evenly tooled top rim and spout to facilitate pouring
- Durable matte finish marking area and white graduations
- Designed from ASTM Specification E960, Type II requirements

Catalog Number	Capacity (mL)	Graduated Interval (mL)	Subdivision (mL)	Approx. OD x Height (mm)	Shelf-Pack Qty.	Case Qty.
14005-250	250	25 to 200	25	67 x 92	12	48
14005-400	400	25 to 325	25	77 x 114	12	48
14005-600	600	50 to 500	50	87 x 122	6	36
14005-1000	1000	100 to 1000	50	107 x 152	6	24
14005-2000	2000	200 to 1800	200	130 x 190	4	8
14005-4000	4000	500 to 3500	500	161 x 252	1	4

Available in Four Fabulous Colors



### Choose KIMAX® Colorware for Easy Identification in the Lab

- Help reduce cross contamination
- Easily identify glassware between labs
- Matte-finish marking spots for use with pencil or marker

### KIMAX® Griffin Low Form Beakers with Double Capacity Scales

- Durable matte finish marking area for use with pencil or marker
- Double capacity scales indicate approximate volumes at various levels
- Designed from ASTM Specification E960, Type I requirements

Catalog Numbers				Capacity (mL)	Grad. Interval (mL)	Subdiv. (mL)	Approx. O.D. x Height (mm)	Case Qty.
Bright Blue	Cool Green	Sunny Yellow	Raging Red					
14000B-50	14000G-50	14000Y-50	14000R-50	50	10 to 40	10	41 x 53	12
14000B-100	14000G-100	14000Y-100	14000R-100	100	20 to 80	10	50 x 71	12
14000B-150	14000G-150	14000Y-150	14000R-150	150	20 to 140	20	57 x 79	12
14000B-250	14000G-250	14000Y-250	14000R-250	250	25 to 200	25	68 x 88	12
14000B-400	14000G-400	14000Y-400	14000R-400	400	25 to 325	25	77 x 106	12
14000B-600	14000G-600	14000Y-600	14000R-600	600	50 to 500	50	88 x 122	6
14000B-1000	14000G-1000	14000Y-1000	14000R-1000	1000	100 to 1000	50	107 x 145	6



14000R

### KIMAX® Erlenmeyer Flasks with Narrow Mouths

- Uniform wall thickness for increased resistance to mechanical shock
- Ceramic scales indicate approximate volumes at various levels
- Designed from ASTM Specification E1404, Type I, Class 1 requirements

Catalog Numbers				Cap. (mL)	Grad. Interval (mL)	Subdiv. (mL)	Rubber Stopper Size	Approx. Widest Dia. x Ht. (mm)	Case Qty.
Bright Blue	Cool Green	Sunny Yellow	Raging Red						
26500B-50	26500G-50	26500Y-50	26500R-50	50	20 to 50	10	1	50 x 78	12
26500B-125	26500G-125	26500Y-125	26500R-125	125	50 to 125	25	5	66 x 108	12
26500B-250	26500G-250	26500Y-250	26500R-250	250	50 to 225	25	6	82 x 130	12
26500B-500	26500G-500	26500Y-500	26500R-500	500	100 to 500	50	7	102 x 174	6
26500B-1000	26500G-1000	26500Y-1000	26500R-1000	1000	250 to 1000	50	9	128 x 213	6



26500B

### KIMAX® Class A Volumetric Flasks

- Single graduation ring blasted on the neck
- Calibrated "To Contain"
- Ground glass stopper supplied
- Durable matte finish marking area for use with pencil or marker
- Designed from ASTM Specification E288, Class A unserialized requirements
- Replacement stopper is 41900R

Catalog Numbers				Capacity (mL)	±Tol. (mL)	Φ Stopper	Approx. Height With Stopper (mm)	Case Qty.
Bright Blue	Cool Green	Sunny Yellow	Raging Red					
28014B-25	28014E-25	28014Y-25	28014R-25	25	0.03	9	118	6
28014B-50	28014E-50	28014Y-50	28014R-50	50	0.05	9	148	6
28014B-100	28014E-100	28014Y-100	28014R-100	100	0.08	13	180	6
28014B-250	28014E-250	28014Y-250	28014R-250	250	0.12	16	250	6
28014B-500	28014E-500	28014Y-500	28014R-500	500	0.20	19	287	6
28014B-1000	28014E-1000	28014Y-1000	28014R-1000	1000	0.30	22	338	1



28014E

**KIMAX® heavy-duty wide-mouth volumetric flasks are available with glass, PTFE or PE stoppers. If you already have stoppers on hand, save money and buy only the flasks. They are graduated to Class A tolerances and feature large, easy-to-read identification markings.**

- Wide mouth facilitates up to 50mL pipet access
- Superior strength, durability and safety from heavy, uniform walls
- Quick identification with large, permanent, volume markings
- Flat interior bottoms for stirring with standard stir bars
- Accuracy - graduated to Class A volumetric tolerances



92812G



92812F



92812P



92812N

## Volumetric Flasks with Glass ⚗ Stoppers

Catalog Number	Cap. (mL)	±Tol. (mL)	⚗ Stopper	Approx. Height with Stopper (mm)	Case Qty.
92812G-5	5	0.08	13	97	6
92812G-10	10	0.08	13	100	6
92812G-20	20	0.08	13	130	6
92812G-25	25	0.08	13	130	6
92812G-50	50	0.08	13	150	6
92812G-100	100	0.10	16	180	6
92812G-200	200	0.20	19	223	6
92812G-250	250	0.20	19	248	6
92812G-500	500	0.20	19	283	6
92812G-1000	1000	0.30	22	335	1
92812G-2000	2000	0.50	27	395	1

## Volumetric Flasks with Color-Coded PTFE ⚗ Stoppers

Catalog Number	Stopper Handle Color	Cap. (mL)	±Tol. (mL)	⚗ Stopper	Approx. Height with Stopper (mm)	Case Qty.
92812F-5	Orange	5	0.08	13	94	6
92812F-10	Orange	10	0.08	13	97	6
92812F-20	Orange	20	0.08	13	127	6
92812F-25	Orange	25	0.08	13	127	6
92812F-50	Orange	50	0.08	13	147	6
92812F-100	Blue	100	0.10	16	175	6
92812F-200	Green	200	0.20	19	217	6
92812F-250	Green	250	0.20	19	269	6
92812F-500	Green	500	0.20	19	300	6
92812F-1000	Yellow	1000	0.30	22	328	1
92812F-2000	Red	2000	0.50	27	392	1

## Volumetric Flasks with Polyethylene ⚗ Stoppers

Catalog Number	Cap. (mL)	±Tol. (mL)	⚗ Stopper	Approx. Height with Stopper (mm)	Case Qty.
92812P-5	5	0.08	13	102	6
92812P-10	10	0.08	13	105	6
92812P-20	20	0.08	13	135	6
92812P-25	25	0.08	13	135	6
92812P-50	50	0.08	13	155	6
92812P-100	100	0.10	16	187	6
92812P-200	200	0.20	19	227	6
92812P-250	250	0.20	19	252	6
92812P-500	500	0.20	19	287	6
92812P-1000	1000	0.30	22	340	1
92812P-2000	2000	0.50	27	400	1

## Volumetric Flasks Without Stoppers

Catalog Number	Cap. (mL)	±Tol. (mL)	⚗ Stopper Size	Approx. Height without Stopper (mm)	Case Qty.
92812N-5	5	0.08	13	77	6
92812N-10	10	0.08	13	87	6
92812N-20	20	0.08	13	110	6
92812N-25	25	0.08	13	110	6
92812N-50	50	0.08	13	130	6
92812N-100	100	0.10	16	160	6
92812N-200	200	0.20	19	200	6
92812N-250	250	0.20	19	225	6
92812N-500	500	0.20	19	260	6
92812N-1000	1000	0.30	22	310	1
92812N-2000	2000	0.50	27	370	1

**KIMAX® RAY-SORB® heavy-duty wide-mouth volumetric flasks are ideal for protecting light-sensitive solutions from short-length lightwaves.**

- Ideal for light-sensitive compounds like Vitamin A
- Wide mouth facilitates up to 50mL pipet access
- Superior strength, durability and safety from heavy, uniform walls
- Quick identification with large, permanent, volume markings
- Flat interior bottoms for stirring with standard stir bars
- Graduated to Class A volumetric tolerances

## RAY-SORB® Volumetric Flasks with Glass ⌘ Stoppers

Catalog Number	Cap. (mL)	±Tol. (mL)	⌘ Stopper	Approx. Height with Stopper (mm)	Case Qty.
92822G-5	5	0.08	13	97	6
92822G-10	10	0.08	13	100	6
92822G-20	20	0.08	13	130	6
92822G-25	25	0.08	13	130	6
92822G-50	50	0.08	13	150	6
92822G-100	100	0.10	16	180	6
92822G-200	200	0.20	19	223	6
92822G-250	250	0.20	19	248	6
92822G-500	500	0.20	19	283	6
92822G-1000	1000	0.30	22	335	1
92822G-2000	2000	0.50	27	395	1

RAY-SORB processed flasks protect contents from short-length lightwaves. They are made from KIMAX KG-33 borosilicate glass, the same as our clear flasks, and then RAY-SORB processed to protect your light-sensitive contents.



## RAY-SORB® Volumetric Flasks with PTFE ⌘ Stoppers

Catalog Number	Stopper Handle Color	Cap. (mL)	±Tol. (mL)	⌘ Stopper	Approx. Height with Stopper (mm)	Case Qty.
92822F-5	Orange	5	0.08	13	94	6
92822F-10	Orange	10	0.08	13	97	6
92822F-20	Orange	20	0.08	13	127	6
92822F-25	Orange	25	0.08	13	127	6
92822F-50	Orange	50	0.08	13	147	6
92822F-100	Blue	100	0.10	16	175	6
92822F-200	Green	200	0.20	19	217	6
92822F-250	Green	250	0.20	19	269	6
92822F-500	Green	500	0.20	19	300	6
92822F-1000	Yellow	1000	0.30	22	328	1
92822F-2000	Red	2000	0.50	27	392	1

## RAY-SORB® Volumetric Flasks with Polyethylene ⌘ Stoppers

Catalog Number	Cap. (mL)	±Tol. (mL)	⌘ Stopper	Approx. Height with Stopper (mm)	Case Qty.
92822P-5	5	0.08	13	102	6
92822P-10	10	0.08	13	105	6
92822P-20	20	0.08	13	135	6
92822P-25	25	0.08	13	135	6
92822P-50	50	0.08	13	155	6
92822P-100	100	0.10	16	187	6
92822P-200	200	0.20	19	227	6
92822P-250	250	0.20	19	252	6
92822P-500	500	0.20	19	287	6
92822P-1000	1000	0.30	22	340	1
92822P-2000	2000	0.50	27	400	1

## RAY-SORB® Volumetric Flasks Without Stoppers

Catalog Number	Cap. (mL)	±Tol. (mL)	⌘ Stopper Size	Approx. Height Without Stopper (mm)	Case Qty.
92822N-5	5	0.08	13	77	6
92822N-10	10	0.08	13	80	6
92822N-20	20	0.08	13	110	6
92822N-25	25	0.08	13	110	6
92822N-50	50	0.08	13	130	6
92822N-100	100	0.10	16	160	6
92822N-200	200	0.20	19	200	6
92822N-250	250	0.20	19	225	6
92822N-500	500	0.20	19	260	6
92822N-1000	1000	0.30	22	310	1
92822N-2000	2000	0.50	27	370	1



### ULTRA-WARE® HPLC Economy Cap Systems

The cap body is manufactured from PTFE and is supplied with a TFE/propylene o-ring and a polypropylene screw collar. The connecting threads on the top of the cap use standard 1/4-28 flangeless fittings. Two of the ports have 1/8" through holes, the third port has a 1/16" through hole. Assembly instructions are included.

The ULTRA-WARE Flat Bottom Reservoirs are manufactured from Type I, Class A borosilicate glass with a plastic safety coating. The plastic coating also blocks virtually all UV light up to 385 nm, preventing photodegradation of light sensitive mobile phases.



#### Economy Three Hole Cap Systems are supplied with:

953913-5000	1 ea.	Economy Three Hole Cap	420822-0018	2 ea.	Flangeless Ferrule, ETFE, 1/8"
953902-series	1 ea.	Ultra-Ware Flat Bottom Reservoir	953913-0001	1 ea.	Nut Plug, ETFE, 1/4-28
953916-3002	1 ea.	All PEEK Inlet/Spurge Filter, 2µm	420823-0018	1 ea.	FEP Teflon® Tubing, 1/8" O.D. x 1/16" I.D. x 10
420821-0018	2 ea.	Flangeless Nut, ETFE, 1/4-28. 1/8"			

Catalog Number	Description	Case Qty.
953930-1002	Economy Three Hole Cap System with 1 Liter Reservoir	1
953930-2002	Economy Three Hole Cap System with 2 Liter Reservoir	1
953930-5002	Economy Three Hole Cap System with 5 Liter Reservoir	1
953930-1003	Economy Three Hole Cap System with 10 Liter Reservoir	1

#### Replacement Parts for Economy Three Hole Caps

Catalog Number	Description	Case Qty.
953913-5000	Replacement Economy Three Hole Cap	1
953913-5001	Body, PTFE	1
953913-5005	Screw Collar, Polypropylene	1

#### Fittings Kit

Kit consists of 20' of 1/8" OD FEP Teflon® tubing, 20 CTFE ferrules and 20 (1/4"-28) ETFE nuts. Not pictured.

Catalog Number	Case Qty.
953882-0000	1



Bottle not included.

### Safety System 3

*Eliminates the safety hazards of aluminum foil-wrapped solvent containers.*

- This unique Solvent Bottle Adapter is made from PBT and converts ULTRA-WARE® GL 45 mobile phase caps to standard 4L solvent bottles for direct connection to your HPLC pump.
- ULTRA-WARE® Economy Three Hole Cap is manufactured from PTFE with a TFE/propylene o-ring and a polypropylene screw collar. Three connecting threads on top of the cap use standard 1/4-28 flangeless fittings. Two ports have 1/8" through-holes for connection to the inlet / spurge filter. The third port has a 1/16" through-hole used as a vent port during sparging.

#### Each Safety System 3 consists of the following:

953913-5000	1 ea.	Economy Three Hole Cap, GL 45
953907-0000	1 ea.	Solvent Bottle Adapter, GL 45 (Systems available with or without adapter. See below.)
953916-3002	1 ea.	Combination Inlet / Spurge Filter, 2µm, PEEKTM
420821-0018	2 ea.	Flangeless Nut, ETFE, 1/4-28 x 1/8" (2 Req'd)
420822-0018	2 ea.	Flangeless Ferrule, ETFE, 1/8" (Optional - 2 Req'd)
953913-0001	1 ea.	Vent Port Plug, ETFE, 1/4-28 (1 Req'd)
420823-0018	1 ea.	Tubing, FEP TEFLON®, 1/8" O.D. x 1/16" I.D. x 10'

Catalog Number	Description
953930-0000	Safety System 3 with GL 45 Bottle Adapter
953930-0001	Safety System 3 without GL 45 Bottle Adapter

#### Unique Filter Combines Functions to Increase Efficiency

Included with your Safety System 3 is the unique Bottom-of-the-Bottle™ Inlet / Spurge Filter. This component combines the functions of an inlet filter with a sparger in a single, convenient device. Sparging bubbles are prevented from entering the mobile phase stream while allowing the pump to draw all but a few milliliters of solvent from the reservoir or bottle. All PEEK construction makes it ideal for virtually all mobile phases. Supplied with 2µm porosity frits and connections for 1/8" O.D. tubing.

Port for sparging line (optional use)

Port for solvent intake line

Filter  
Catalog No.  
953916-3002

Draws solvent from bottom of solvent bottle

Filters incoming sparging gas (optional use)

## Plastic-Coated ULTRA-WARE® Reservoirs

ULTRA-WARE Reservoirs have been specially designed for the preparation, storage and delivery of all liquid chromatography mobile phases. Each ULTRA-WARE Reservoir is manufactured from the most chemically inert glass available to prevent the leaching of any extractables into the mobile phase solvents. They are then externally coated with plastic containing an added ultraviolet (UV) blocking agent. In case of an accident, the plastic safety coating helps retain glass fragments and allows a reasonable amount of time for the safe disposal of the liquid contents. The plastic coating also blocks virtually all UV light up to 385 nm, preventing photodegradation of light sensitive reagents.

ULTRA-WARE Reservoirs are recommended for use under vacuum for filtration and vacuum degassing of mobile phase solvents. ULTRA-WARE Reservoirs can also be used at internal pressures up to 6 psig for helium sparging and blanketing of the mobile phase. The conical bottom reservoirs deliver virtually all of the mobile phase without dangerous reservoir tilting. All ULTRA-WARE Reservoirs are supplied with GL 45 screw thread. \*Patent No. Des. 292,824

### Conical Bottom HPLC Reservoirs without Graduations

Catalog Number	Capacity	Approx. Overall Height x Dia.	Case Qty.
953901-0252	250 mL	203 x 85 mm	1
953901-0502	500 mL	230 x 105 mm	1
953901-1002	1 liter	275 x 130 mm	1
953901-2002	2 liter	319 x 150 mm	1
953901-5002	5 liter	373 x 205 mm	1
953901-1003	10 liter	433 x 255 mm	1
953901-2003	20 liter	578 x 315 mm	1

### Conical Bottom HPLC Reservoirs with Graduations

Catalog Number	Capacity	Approx. Overall Height x Dia.	Case Qty.
953922-0252	250 mL	203 x 85 mm	1
953922-0502	500 mL	230 x 105 mm	1
953922-1002	1 liter	275 x 130 mm	1
953922-2002	2 liter	319 x 150 mm	1
953922-5002	5 liter	373 x 205 mm	1
953922-1003	10 liter	433 x 255 mm	1
953922-2003	20 liter	578 x 315 mm	1

### Conical Bottom HPLC Reservoirs with Side Necks and Graduations

Side neck allows addition of filtered solvent without removing delivery cap.

Catalog Number	Capacity	Approx. Overall Height x Dia.	Case Qty.
953910-2002	2 liter	319 x 150 mm	1
953910-5002	5 liter	373 x 205 mm	1
953910-1003	10 liter	433 x 255 mm	1
953910-2003	20 liter	578 x 315 mm	1

### Flat Bottom HPLC Reservoirs without Graduations

Catalog Number	Capacity	Approx. Overall Height x Dia.	Case Qty.
953902-0252	250 mL	133 x 73 mm	1
953902-0502	500 mL	165 x 89 mm	1
953902-1002	1 liter	205 x 111 mm	1
953902-2002	2 liter	250 x 138 mm	1
953902-5002	5 liter	320 x 186 mm	1
953902-1003	10 liter	400 x 234 mm	1
953902-2003	20 liter	490 x 300 mm	1

### Flat Bottom HPLC Reservoirs with Graduations

Catalog Number	Capacity	Approx. Overall Height x Dia.	Case Qty.
953932-0252	250 mL	203 x 85 mm	1
953932-0502	500 mL	230 x 105 mm	1
953932-1002	1 liter	275 x 130 mm	1
953932-2002	2 liter	319 x 150 mm	1
953932-5002	5 liter	373 x 205 mm	1
953932-1003	10 liter	433 x 255 mm	1
953932-2003	20 liter	578 x 315 mm	1



Specifications  
ULTRA-WARE HPLC Reservoirs

Materials:

Reservoir: Type I, Class A, Borosilicate Glass  
Plastic Coating: PVC with UV blocking agent

Screw Thread: GL 45  
Operating Pressure: -1.0 to 0.4 bar  
UV Transmittance: <1% up to 385 nm



953906

### ULTRA-WARE® Solvent Pickup Adapter

Designed to be used with the Five Valve, Four Valve and Filtration caps to provide safe, in-line filtration that replaces the traditional pour-and-wait funnel filtration method. The unique BEVEL-SEAL® makes a vacuum tight o-ring connection to the PTFE tubing. The HI-VAC® valve is easier to open under vacuum than the standard stopcock. Closing the valve provides vacuum degassing after filtration. Each unit is supplied with 3 feet (91 cm) of 1/4" O.D. FEP Teflon® tubing. Valve o-ring size is 010 and sidearm o-ring size is 108.

Catalog Number	Description	Case Qty.
953906-0047	Pickup Adapter, Standard, 47 mm	1
953906-6347	Pickup Adapter, THF-Resistant, 47 mm	1
953906-0090	Pickup Adapter, Standard, 90 mm	1
953906-6390	Pickup Adapter, THF-Resistant, 90 mm	1

#### Replacement Parts

953906-0001	(1) Valve Plug Assembly, Std.	1
953906-6301	(1) Valve Plug Assembly, THF	1
953906-0002	(2) Glass Pickup Adapter Body, 47mm	1
953906-0092	(2) Glass Pickup Adapter Body, 90mm	1
410119-1508	(3) Cap, Nylon, 15-415, 8.5mm, 12/Pkg.	12

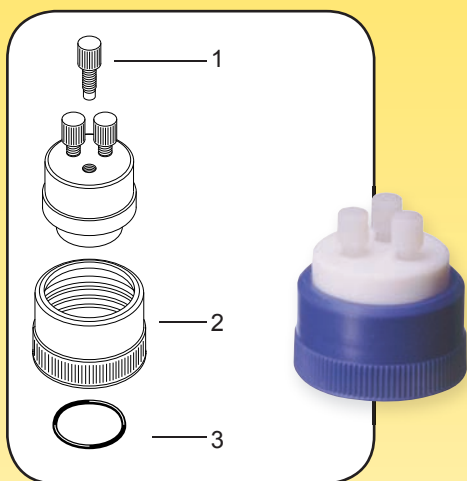

953913-0000

### ULTRA-WARE® Three Hole Delivery Cap

Three holes have 1/4-28 threads top and bottom with 1/8" I.D. holes through to accept 1/8" O.D. PTFE tubing. Body is PTFE. Supplied complete with three 1/4-28 CTFE plugs and a TFE/propylene o-ring.

Catalog Number	Description	Cap Thread	Case Qty.
953913-0000	Three Hole Cap	GL 45	1

#### Replacement Parts

953913-0001	(1) Plug, ETFE, 1/4-28	1
953903-0005	(2) Screw Cap, GL 45	1
758260-0216	(3) O-Ring, TFE/Propylene, Size 216	1

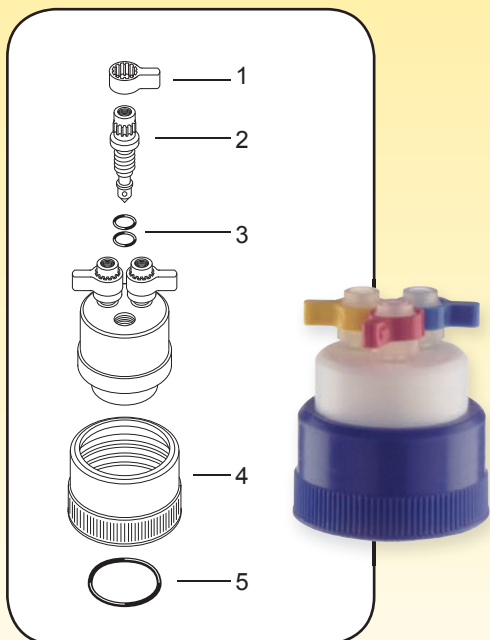

953903-0000

### ULTRA-WARE® Three Valve Delivery Cap

Three on-off CTFE valves have 1/4-28 threads top and bottom. Valve body is PTFE. Valve stem is CTFE. O-ring material for valve stem and lower seal is TFE/propylene.

Catalog Number	Description	Cap Thread	Case Qty.
953903-0000	Three Valve Cap	GL 45	1

#### Replacement Parts

953903-0002	(1) Valve Handle, Blue	1
953903-0003	(1) Valve Handle, Red	1
953903-0004	(1) Valve Handle, Yellow	1
953903-0042	(2) Valve Stem, CTFE, Short	1
758260-0008	(3) O-Ring, TFE/Propylene, Size 008 (2 required per CTFE Valve Stem)	1
953903-0005	(4) Screw Cap, GL 45	1
758260-0216	(5) O-Ring, TFE/Propylene, Size 216	1

THF-resistant versions of ULTRA-WARE® caps are also available. Please call 888-546-2531 for more information.

### ULTRA-WARE® Filtration Cap

Body is constructed of glass-filled PTFE with a vacuum adapter for 1/4" I.D. tubing. Upper screw clamp holds a solvent pickup adapter or funnel. Coarse fritted glass filter support is removable. Supplied with a PTFE/propylene o-ring.

Catalog Number	Filter Diameter	Cap Thread	Case Qty.
953915-0047	47 mm	GL 45	1

#### Replacement Parts

953914-0002	(1) Upper Screw Clamp, 47 mm	1
953914-0001	(2) Coarse Porosity Glass Support Frit, 47 mm	1
953915-0001	(3) Hose Barb, PFA, 1/4"	1
953914-0006	(4) Drip Tip, PTFE	1
953981-0004	(5) Lower Cap Retainer Ring	1
953981-0005	(6) Lower Screw Cap, GL 45	1
758292-0122	(7) O-Ring, Ethylene Propylene, Size 122, 10/Pkg.	10

### ULTRA-WARE® Four Valve Filtration / Delivery Cap

Cap combines the mobile phase filtration, sparging/degassing, storage and delivery functions. Tubing connections are made in the back of the cap, reducing the typical clutter of tubing at the reservoirs. An integral check valve in the sparge port prevents the mobile phase from backing up into the gas lines. A pressure release valve prevents the reservoir from being accidentally over-pressurized. The 1/4-28 fitting connections allow easy connection to any HPLC pump system. Cap body is manufactured from glass-filled PTFE. Cap will fit any reservoir or bottle with a GL 45 thread. Patent No. 5,397,467

Catalog Number	Filter Diameter	Cap Thread	Case Qty.
953981-0047	47 mm	GL 45	1

#### Replacement Parts

953914-0002	(1) Upper Screw Clamp, 47 mm	1
953914-0001	(2) Coarse Porosity Glass Support Frit, 47 mm	1
758260-0008	(3) O-Ring, TFE/Propylene, Size 008 (2 req'd. per CTFE Valve Stem)	1
953981-0001	(4) Valve Stem, CTFE, Short (for Sparge and Pump Ports)	1
953981-0002	(4) Valve Stem, CTFE, Long (for Filter and Vent Ports)	1
953914-0006	(5) Drip Tip, PTFE	1
953981-0003	(6) Check Valve with Retainer	1
953981-0004	(7) Lower Cap Retainer Ring	1
953981-0005	(8) Lower Screw Cap, GL 45	1
758292-0122	(9) O-Ring, Ethylene Propylene, Size 122, 10/Pkg.	10

THF-resistant versions of ULTRA-WARE® caps are also available. Please call 888-546-2531 for more information.



### 90 mm Conversion Base for ULTRA-WARE® Caps

Converts the Five Valve, Four Valve and Filtration caps to use 90 mm filter membranes, providing up to four times faster filtration. The conversion base is manufactured from glass-filled PTFE and is supplied with a coarse porosity glass support frit and an upper screw clamp. Requires a 90 mm Solvent Pickup Adapter, 953906-0090 or THF-resistant 953906-6390.

Catalog Number	Description	Case Qty.
953984-0090	90 mm Conversion Base	1

#### Replacement Parts

953914-0092	(1) Upper Screw Clamp, 90 mm	1
953914-0091	(2) Glass Support Frit, Coarse, 90 mm	1

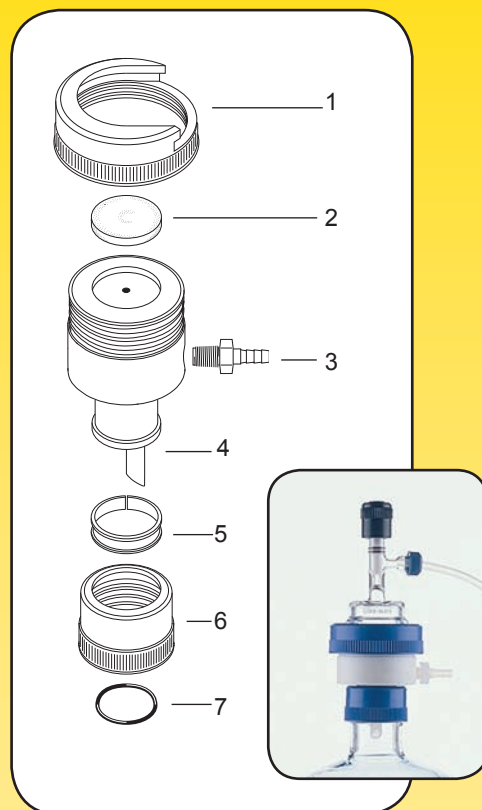

953915-0047

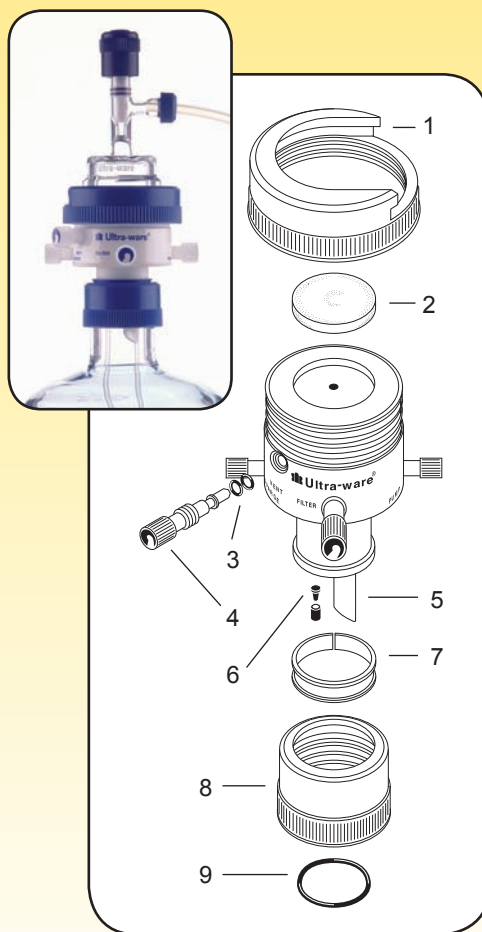

953981-0047

### ULTRA-WARE® Five Valve Recirculation / Filtration Cap

Designed to permit the recirculation of mobile phase back into the reservoir while maintaining the helium sparged environment. Cap also performs stepwise filtration, sparging/degassing, storage and delivery to the HPLC pump. An integral check valve prevents mobile phase from backing up into the gas lines. A pressure release valve protects the reservoir from being accidentally over-pressurized. The 1/4-28 fitting connections allow easy connection to any HPLC pump system. Cap body is manufactured from glass-filled PTFE. Cap will fit any reservoir or bottle with a GL 45 thread. Patent No. 5,397,467

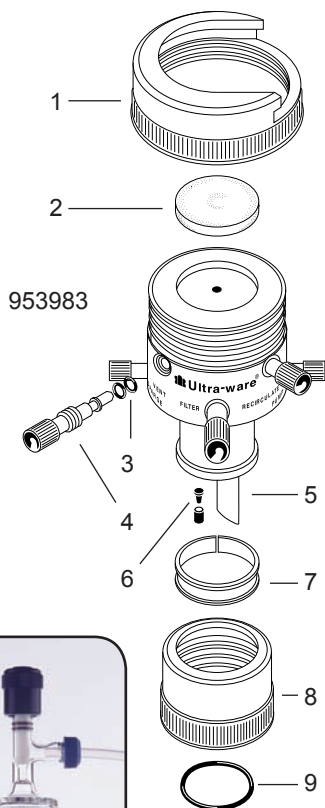

Catalog Number	Filter Diameter	Cap Thread	Case Qty.
953983-0047	47 mm	GL 45	1

#### Replacement Parts

953914-0002	(1) Upper Screw Clamp, 47 mm	1
953914-0001	(2) Coarse Porosity Glass Support Frit, 47 mm	1
758260-0008	(3) O-Ring, TFE/Propylene, Size 008 (2 required per Valve Stem)	1
953981-0001	(4) Valve Stem, CTFE, Short (for Sparge and Pump Ports)	1
953981-0002	(4) Valve Stem, CTFE, Long (for Filter, Vent and Recirculate Ports)	1
953914-0006	(5) Drip Tip, PTFE	1
953981-0003	(6) Check Valve with Retainer	1
953981-0004	(7) Lower Cap Retainer Ring	1
953981-0005	(8) Lower Screw Cap, GL 45	1
758292-0122	(9) O-Ring, Ethylene Propylene, Size 122, 10/Pkg.	10

THF-resistant versions of ULTRA-WARE® caps are also available. Please call 888-546-2531 for more information.

### 90 mm Conversion Base for ULTRA-WARE® Caps

Converts the Five Valve, Four Valve and Filtration caps to use 90 mm filter membranes, providing up to four times faster filtration. The conversion base is manufactured from glass-filled PTFE and is supplied with a coarse porosity glass support frit and an upper screw clamp. Requires a 90 mm Solvent Pickup Adapter, 953906-0090 or THF-resistant 953906-6390.

1. Coarse Glass Frit



2. Screw Clamp

Catalog Number	Description	Case Qty.
953984-0090	90 mm Conversion Base	1

#### Replacement Parts

953914-0092	(1) Upper Screw Clamp, 90 mm	1
953914-0091	(2) Glass Support Frit, Coarse, 90 mm	1

For a complete listing of chromatography columns and fittings, visit our website: [www.kimble-chase.com](http://www.kimble-chase.com)

## Care and Use Ground-Glass Surfaces

Ground-glass joints and stopcocks should never be used when dry. Although ground-glass surfaces seal well without the use of lubricants, it is advisable to lubricate them to prevent sticking and breakage. Ground surfaces must be cleaned prior to lubrication—dust, dirt and particulate matter may score the surface and cause leakage.

Different lubricants are used for these operating conditions:

- Silicone grease — high temperature and high vacuum
- Glycerin — long term reflux or extraction
- Hydrocarbon grease — general laboratory use

### Lubricating Ground-Glass Joints

1. Lubricate joints that must be airtight and when glassware contains strong alkaline solutions.
2. Lubricate only the upper part of the inner joint. A properly lubricated joint appears clear, without striations.
3. Do not allow grease to come in contact with vapor or liquid and cause contamination.

### Lubricating Stopcocks

Spread two circular bands of grease around the stopcock plug. Insert the plug into the barrel and twist several times until the assembly is completely transparent. Be careful not to use too much lubricant or the bore will become plugged.

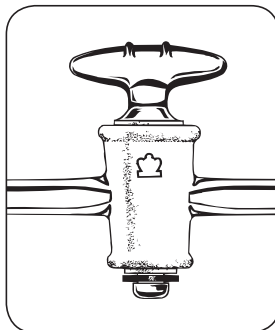

## Care and Use HI-VAC® PTFE VALVES

1. Valves are assembled with Viton® O-rings, suitable for use with oxidizing and NON-POLAR compounds at temperatures from -23°C to 204°C.
2. All elastomers have outgassing rates higher than glass. Long pump-down periods will typically reduce these rates by a factor of ten. Vacuum systems using PTFE valves normally operate at pressures up to 10<sup>-6</sup> mm Hg. Heating of this valve during pump-down with an air heat gun will improve ultimate vacuum.
3. O-rings should be lubricated with a thin film of vacuum grease to prolong life and reduce leakage by allowing the o-ring to slip easily along the tube. Excess grease should be thoroughly wiped off.
4. Any leakage across the o-ring stem seal occurs mainly on the inward movement. Turning the stem in and out during pump-down helps evacuate the space between the two stem o-rings. One o-ring may be removed if preferred, improving performance under some conditions.
5. O-rings may be removed from the stem by pushing the o-ring into the groove with thumb and forefinger, distorting ring sufficiently to form a small loop which can be "picked up" and the o-ring pulled off of the stem without damaging surfaces.

®Reg. T.M. E.I. DuPont Co.

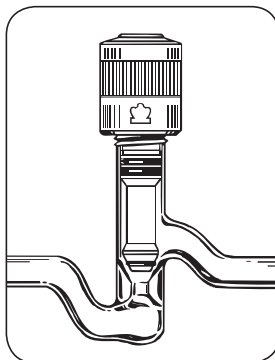

## Care and Use — Stopcocks with Plugs Made of PTFE (polytetrafluoroethylene)

Kimble stopcock plugs of PTFE are made of the most chemically inert material in laboratory use today. Only a few chemicals have any effect on PTFE and these only at elevated temperatures and pressures. The material is extremely tough, durable and heat resistant, with minimal moisture-absorption. It remains non-brittle even at sub-zero temperatures.

To obtain maximum performance from your PTFE stopcock plugs observe the following hints:

1. To clean new plugs, carefully disassemble, lift plug free of glass barrel, and rinse all parts of plug and barrel in acetone. After drying, reassemble and the stopcock is ready for use. (**Do not use abrasive materials to clean either plug or barrel at any time.**)
2. The PTFE washer must always be placed adjacent to the end of the glass barrel, to secure minimal friction when turning. When properly tightened, the plug will be slightly more resistant to turning than a lubricated glass plug.
3. PTFE plugs can be easily scored around the bore if rotated when solid particles are lodged between plug and barrel, or project beyond mating edges of glass parts. Once scored, the plug may leak.
4. Do not use a PTFE stopcock plug on a vessel used for long time storage of liquids known to attack glass, since the surface of the barrel may become roughened, and leakage may occur between the plug and barrel causing a potential safety hazard.
5. If PTFE plugs are used with liquids corrosive to glass, such as alkalis, rinse the stopcock thoroughly with water after use. Do not allow the liquid to evaporate. The concentrated solution remaining will attack the glass surface: and the eventual solids may also mar the surface of PTFE if the plug is then rotated.
6. When not in use, store in a dust-free area with plug loosened within the glass barrel.

Although tough and unbreakable, PTFE is softer than glass and has a tendency to conform to the glass surface, including eventual expansion into the hollow parts of the barrel. Do not interchange PTFE and glass plugs.



Don't leave in detergent solutions for prolonged periods.



Don't pipet by mouth.



Don't apply direct heat.

### Cleanliness of Volumetric Glass Apparatus

The usual criterion of cleanliness of glass apparatus is uniform wetting of the surface by distilled water. Certain contaminants, especially grease, adhering to the walls prevent them from being uniformly wetted, and there is a tendency for water to collect into drops. Imperfect wetting causes irregularities in capacity of volumetric glassware by distorting the meniscus, and also by affecting the volume of the residue adhering to the walls after emptying instruments calibrated to deliver the indicated volume.

Even when the surface of the vessel is uniformly wetted, variations in the apparent capacity still may occur, due to contamination of the liquid surface by minute quantities of fatty or other organic substances that produce a change in surface tension affecting the shape of the meniscus. The cleaning, rinsing and drying, therefore, must be carried out in such a way as to prevent this from happening.

The choice of the procedure to be used in cleaning glassware depends on the nature of the contaminant. In many cases special reagents or methods must be used to remove a particular substance. Before listing the more important methods, it is desirable to make a few general statements.

#### Glass

Glasses used in chemical apparatus have excellent resistance to acids, except hydrofluoric. Strong alkaline solutions, such as hot caustic solutions, will attack any glass if contact is prolonged. This is true even though a particular glass may not exhibit any visible effect, due to the solubility of the reaction products. Dilute detergent solutions, up to about 2% strength, will have no serious effect on the glass unless the glass is exposed for unnecessarily long periods or the detergent is allowed to dry on the glass.

#### Colored Graduations

The scales and inscriptions of many items of Kimble glassware are colored by staining a thin layer of the glass. Since the colored portion is of the same composition as the glass object, the resistance to chemical attack is the same as that of the rest of the glass. Here, the color can be removed only by dissolving a layer of glass from the surface.

Some Kimble volumetric glassware has fused-on, ceramic enamel printed lines and inscriptions. These fused-on enamels are quite resistant to acids and alkalis. In most cases they should last as long as the piece of apparatus if cared for properly. However, by their nature, they cannot be as resistant as the ware to which they adhere. Consequently, the graduated lines should not be subjected to prolonged immersion in acids or alkalis. Whenever the lines are wetted by reagents, they should be rinsed as soon as conveniently possible.

#### Safety Precautions

With many pieces of glassware, it is necessary or desirable to fill by suction when cleaning. Do not pipet acid or other cleaners by mouth. In fact, do not pipet by mouth at all. Use hand held, manual or electronic pipetting aids.

#### Abrasives

Do not use abrasives on glassware, particularly volumetric ware. The surface will be marred in time, and the resultant scratches may prevent proper drainage or act as resting places for adulterants, which will be difficult to remove.

#### Water for Rinsing

When preparing a piece of glassware for calibration, rinsing with tap water should be followed by a thorough rinsing with distilled water. Sufficient material may be deposited on the surface by tap water to cause erratic results, particularly with small items, even though water wets the surface uniformly. Even in ordinary cleaning processes, the use of deionized water is recommended.

#### Adherent Organic Residues

Never attempt to remove such residues by the application of direct heat. Permanent strains may be introduced and, what is more important, the calibration of volumetric apparatus may be changed.

### Cleaning Methods for Glassware

Care should be exercised when using most cleaning solutions, as they can cause skin irritations or severe burns on contact. Dilute solutions become concentrated as the water evaporates; therefore, always flush the exposed area immediately with large quantities of water.

The list of methods given here is by no means complete, but offers a fairly wide variety and should cover all the usual contaminants, as well as the more important special cases.

Frequently it is desirable to give glassware a preliminary rinse or soak with organic solvent to remove grease, followed by a water rinse. The rinsing with water must be done thoroughly if acid will be used later to clean the glassware.

Unless autoclaving is necessary, glassware should be cleaned as soon as possible after use to avoid setting and caking of residues. Pipets, for example, may be placed in a convenient jar containing a weak antiseptic solution, immediately after use. Autoclaving is necessary to disinfect glassware that may have been used to contain potentially dangerous biological fluids.

There is a wide variety of cleaning agents available that will remove surface contaminants such as silicone and other organic and biological residues, blood residues and other contaminants that may interfere with trace analyses. These cleaners are available in biodegradable, phosphate-free and chromium-free formulations if desired and can be obtained from laboratory supply houses.

**NOTE:** If wiping or other mechanical cleaning action is necessary, it should be done gently using non-abrasive cleaners and wiping materials. The use of abrasive materials will damage the glass surface, degrading its inherent strength.

Specific contaminants may require specialized cleaning methods and some are given here:

**Pernganganate stains** - Use a mixture of equal volume of 3% sulfuric acid and 3% hydrogen peroxide.

**Iron stains** - Use a solution containing one part hydrochloric acid and one part water.

**Bacteriological material** - Glassware should be soaked in a suitable disinfectant solution or steam autoclaved followed by cleaning with a suitable agent.

**CAUTIONS:** Before using any cleaning solution, refer to its Material Safety Data Sheet for precautions to be observed during use. Some of the cleaning materials used may leave trace residue unless a rinsing process is carried out thoroughly. While such traces may not be harmful if the object of cleaning is to prepare the glassware for calibration, they can give trouble in certain laboratory operations. When glassware is to be calibrated, the final rinsings must be distilled water.

If an article is to be dried after cleaning, as is necessary for all vessels marked "To Contain", ethyl alcohol or acetone (American Chemical Society Specification) may be used. Drying may be hastened by blowing clean, dry air into the vessel (or sucking the air through the vessel).

Efficient air filters must be provided to remove any particles of oil or dirt from compressed air. Drying should be done in a fume hood.

### General Recommendations

#### A. Avoid Abrasions and Serious Personal Injury

An abrasion reduces the strength of glass, making it more susceptible to breakage under impact and/or thermal shock. Thermal shock may result from sudden changes in temperature or use on either a burner or hot plate. Serious injuries could result if breakage occurs while glass holds heated and/or corrosive liquid.

#### B. Recommended Glassware Cleaning and Handling Procedures

##### Proper Cleaning Procedures:

1. Washing machines may be used. Support racks on the washer must be well maintained. The support pins should be coated with a non-abrasive material to prevent metal to glass contact and scratching.
2. For manual washing, use only plastic core brushes that have soft, non-abrasive bristles. Soft, clean sponges or other wiping materials may be used.

**DO NOT USE THESE BRUSHES OR WIPING MATERIALS WITH ABRASIVE CLEANERS.** Keep them clean. Scotch Brite® and similar scouring pads will scratch glass and should not be used.

3. Inspect glassware before each use and discard if scratched, chipped, cracked

### General Recommendations for the Care and Use of KimCote® Plastic-Coated Glassware

- Do not expose coated ware to dry heat above 110° C (230°F)
- Do not place coated ware over direct heat or open flames
- Do not use coated ware on hot plates
- Steam autoclaving temperature is 120°C (250°F) maximum
- Freezing temperature is -20°C (-4°F) maximum
- Coated ware is dishwasher safe as long as the above guidelines are followed
- Coated ware is microwavable provided standard microwave safety guidelines are followed
- Labeling and marking on the coating is permitted

An MSDS and a certificate of compliance are available by contacting Kimble Chase customer service.





### When Using Glassware

- Avoid abrasions and impacts
- Use proper cleaning procedures
- Use appropriate heating methods
- Observe all lab safety guidelines



or damaged in any way.

4. Many commercial glass cleaners are available. Follow the manufacturers' directions for the use of these products since some are corrosive and can damage the glass.
5. Organic solvents are acceptable cleaning agents when conditions warrant their use.
6. Do not soak KimCote® plastic-coated glassware for long periods of time; this will result in shortening the life of the coating. Do not allow used KimCote® plastic-coated glassware to sit unwashed for long periods of time, as this will make cleaning more difficult.

#### Improper Cleaning Procedures:

1. Do not place metal or other hard objects, such as spatulas, glass stirring rods, or brushes with metal parts, inside the glassware. This will scratch the glass and cause eventual breakage and injury.
2. Do not use strong alkaline products and hydrofluoric acid as cleaning agents, they are glass dissolvers and can damage the glassware and eventually cause breakage which can result in injury.
3. Do not use any abrasive cleansers, including soft cleansers (i.e. Ajax®, Comet®, Old Dutch®, Soft Scrub®, etc.), as these will scratch the glass and cause eventual breakage and injury.
4. Do not place hands inside glassware while wearing any jewelry, particularly diamond rings, as these will score the inside of the glassware and eventually cause breakage and injury.
5. Do not heat glassware to temperatures (>800°F) needed to burn out carbon residues. This will result in the introduction of permanent stresses in the glass that will eventually cause the glassware to break resulting in possible injury.
6. KimCote® plastic-coated glassware should not be cleaned with harsh, chemical grade detergents; use a non-abrasive grade detergent. If using a dishwasher or dryer, avoid temperatures greater than 110°C (230°F). Scouring pads and brushes are not recommended for use on KimCote® plastic-coated glassware.

#### C. Avoid Impact

Glass will break as a result of impact. Use care when handling to avoid impacting hard objects, such as spigots, other glassware, counter tops, etc.

#### D. Heating Uncoated Glassware

1. Use wire gauze when heating over open flame.
2. Use either low or medium heat settings when using a hot plate. High hot plate settings will cause excessive localized heating of the glassware and will eventually cause breakage and possible injury.
3. Do not heat glassware designated as heavy duty unless recommended by manufacturer. Even though these items have added mechanical strength, they are more susceptible to breakage from thermal shock when heated.
4. Do not allow the contents of the container to boil dry as this may induce permanent stresses that will eventually cause breakage. Discard containers that have been boiled dry.

DO NOT evacuate or pressurize glassware unless recommended in the current Kimble Chase Laboratory catalog.

NOTE: KimCote® plastic-coated glassware should not be placed on a hot plate or exposed to direct heat or flames. It can be steam autoclaved at 121°C (250°F) for 30 minutes.

#### E. Centrifuge Tubes

RCF values can be significantly reduced if the glass tubes have been scratched or otherwise physically abused resulting in surface damage and lowered glass strength. Refer to the current Kimble Chase Laboratory catalog.

## Catalog Number Index

Catalog No.	Page	Catalog No.	Page	Catalog No.	Page	Catalog No.	Page	Catalog No.	Page	Catalog No.	Page
14000B-50	9	27060-500	5	885462-0020	7	92822G-250	11	953914-0001	15	KC25165-100	6
14000B-100	9	27060-1000	5	885462-0021	7	92822G-500	11	953914-0002	15	KC25165-200	6
14000B-150	9	27060-2000	5	885462-0022	7	92822G-1000	11	953914-0006	15	KC25165-500	6
14000B-250	9	27060-4000	5	885462-0023	7	92822G-2000	11	953914-0091	15	KC25165-1000	6
14000B-400	9	27065-250	5	885462-0024	7	92822N-5	11	953914-0092	15	KC25330-100	6
14000B-600	9	27065-500	5	885462-0025	7	92822N-10	11	953915-0001	15	KC25330-250	6
14000B-1000	9	27065-1000	5	92812F-5	10	92822N-20	11	953915-0047	15	KC25330-500	6
14000G-50	9	27065-2000	5	92812F-10	10	92822N-25	11	953922-0252	13	KC25330-1000	6
14000G-100	9	27065-4000	5	92812F-20	10	92822N-50	11	953922-0502	13	KC25330-2000	6
14000G-150	9	27070-250	5	92812F-25	10	92822N-100	11	953922-1002	13	KC26720-250	4
14000G-250	9	27070-500	5	92812F-50	10	92822N-200	11	953922-1003	13	KC26720-500	4
14000G-400	9	27070-1000	5	92812F-100	10	92822N-250	11	953922-2002	13	KC26720-1000	4
14000G-600	9	27070-2000	5	92812F-200	10	92822N-500	11	953922-2003	13	KC26720-2000	4
14000G-1000	9	27070-4000	5	92812F-250	10	92822N-1000	11	953922-5002	13	KC28014-100	6
14000R-50	9	28014B-25	9	92812F-500	10	92822N-2000	11	953930-0000	12	KC28014-250	6
14000R-100	9	28014B-50	9	92812F-1000	10	92822P-5	11	953930-0001	12	KC28014-500	6
14000R-150	9	28014B-100	9	92812F-2000	10	92822P-10	11	953930-1002	12	KC28014-1000	6
14000R-250	9	28014B-250	9	92812G-5	10	92822P-20	11	953930-1003	12	KC28014-2000	6
14000R-400	9	28014B-500	9	92812G-10	10	92822P-25	11	953930-2002	12	KC29048T-125	6
14000R-600	9	28014B-1000	9	92812G-20	10	92822P-50	11	953930-5002	12	KC29048T-250	6
14000R-1000	9	28014E-25	9	92812G-25	10	92822P-100	11	953932-0252	13	KC29048T-500	6
14000Y-50	9	28014E-50	9	92812G-50	10	92822P-200	11	953932-0502	13	KC29048T-1000	6
14000Y-100	9	28014E-100	9	92812G-100	10	92822P-250	11	953932-1002	13	KC29048T-2000	6
14000Y-150	9	28014E-250	9	92812G-200	10	92822P-500	11	953932-1003	13	KC45066-13100	8
14000Y-250	9	28014E-500	9	92812G-250	10	92822P-1000	11	953932-2002	13	KC45066-16125	8
14000Y-400	9	28014E-1000	9	92812G-500	10	92822P-2000	11	953932-2003	13	KC45066-20150	8
14000Y-600	9	28014R-25	9	92812G-1000	10	953760-0122	5	953932-5002	13	KC45066-25150	8
14000Y-1000	9	28014R-50	9	92812G-2000	10	953760-1002	5	953981-0001	15		
14005-250	8	28014R-100	9	92812N-5	10	953760-2002	5	953981-0002	15		
14005-400	8	28014R-250	9	92812N-10	10	953760-4002	5	953981-0003	15		
14005-600	8	28014R-500	9	92812N-20	10	953882-0000	12	953981-0004	15		
14005-1000	8	28014R-1000	9	92812N-25	10	953901-0252	13	953981-0005	15		
14005-2000	8	28014Y-25	9	92812N-50	10	953901-0502	13	953981-0047	15		
14005-4000	8	28014Y-50	9	92812N-100	10	953901-1002	13	953983-0047	16		
14395C-45	3	28014Y-100	9	92812N-200	10	953901-1003	13	953984-0090	15		
14395C-451	3	28014Y-250	9	92812N-250	10	953901-2002	13	KC14395-100	3		
14395C-453	3	28014Y-500	9	92812N-500	10	953901-2003	13	KC14395-250	3		
14395E-452	3	28014Y-1000	9	92812N-1000	10	953901-5002	13	KC14395-500	3		
14395H-452	3	410119-1508	14	92812N-2000	10	953902-0252	13	KC14395-1000	3		
14395M-45	3	45066B-13	8	92812P-5	10	953902-0502	13	KC14395-2000	3		
14395P-45	3	45066B-15	8	92812P-10	10	953902-1002	13	KC14395-5000	3		
14950C-12	2	45066B-18	8	92812P-20	10	953902-1003	13	KC14395-10000	3		
14950S-321	2	45066B-24	8	92812P-25	10	953902-2002	13	KC14607-250	1		
14950S-2321	2	45066C-13	8	92812P-50	10	953902-2003	13	KC14607-500	1		
26500B-50	9	45066C-15	8	92812P-100	10	953902-5002	13	KC14607-1000	1		
26500B-125	9	45066C-18	8	92812P-200	10	953903-0000	14	KC14607-2000	1		
26500B-250	9	45066C-24	8	92812P-250	10	953903-0002	14	KC14607-5000	1		
26500B-500	9	653200-2000	1	92812P-500	10	953903-0003	14	KC14607-10000	1		
26500B-1000	9	653210-2000	1	92812P-1000	10	953903-0004	14	KC14607-20000	1		
26500G-50	9	749600-0015	7	92812P-2000	10	953903-0005	14	KC14950-25	2		
26500G-125	9	749600-0050	7	92822F-5	11	953903-0042	14	KC14950-35	2		
26500G-250	9	749610-0015	7	92822F-10	11	953906-0001	14	KC14950-120	2		
26500G-500	9	749610-0050	7	92822F-20	11	953906-0002	14	KC14950-500	2		
26500G-1000	9	758260-0008	14	92822F-25	11	953906-0047	14	KC14960-4	1		
26500R-50	9	758260-0216	14	92822F-50	11	953906-0090	14	KC14960-9	1		
26500R-125	9	758292-0122	15	92822F-100	11	953906-0092	14	KC15093-10000	2		
26500R-250	9	885451-0020	7	92822F-200	11	953906-6301	14	KC15093-20000	2		
26500R-500	9	885451-0021	7	92822F-250	11	953906-6347	14	KC15097-100	2		
26500R-1000	9	885451-0022	7	92822F-500	11	953906-6390	14	KC15097-250	2		
26500Y-50	9	885451-0023	7	92822F-1000	11	953910-1003	13	KC15097-500	2		
26500Y-125	9	885451-0024	7	92822F-2000	11	953910-2002	13	KC15097-1000	2		
26500Y-250	9	885451-0025	7	92822G-5	11	953910-2003	13	KC15097-2000	2		
26500Y-500	9	885460-0020	7	92822G-10	11	953910-5002	13	KC20028W-100	4		
26500Y-1000	9	885460-0021	7	92822G-20	11	953913-0000	14	KC20028W-250	4		
27060-25	5	885460-0022	7	92822G-25	11	953913-0001	14	KC20028W-500	4		
27060-50	5	885460-0023	7	92822G-50	11	953913-5000	12	KC20028W-1000	4		
27060-125	5	885460-0024	7	92822G-100	11	953913-5001	12	KC20028W-2000	4		
27060-250	5	885460-0025	7	92822G-200	11	953913-5005	12	KC25165-50	6		



## Choose KimCote® Plastic-Coated Glassware for an Added Measure of Safety!

- Helps prevent and contain spills in the event of glassware breakage
- Ultra-clear for improved sample viewing
- Non-slip surface — wet or dry
- Autoclavable and chemical resistant
- Durable and odor-free

KimCote protective glassware coating goes beyond traditional coatings. Should a break occur, KimCote will reduce the hazards of shattered glass and leakage of toxic or corrosive chemicals. It's ultra-clear, extremely durable, autoclavable and resistant to many common laboratory chemicals. KimCote's unique texture also provides a non-slip handling surface, wet or dry.

### Use KimCote anywhere you want to increase safety!

- Pressurized glassware
- Chemical storage
- Transportation of samples
- Handling of hazardous chemicals, harmful biologicals and acids



## Estamos aqui para ajudar.

Se você não encontrar o que precisa, ligue para nós. Nosso grupo de atendimento ao cliente ficará feliz em discutir suas necessidades especiais.

### Central de atendimento WAISER: 11 2958-9500

WAISER Científica Ltda.  
Rua Cumaí, 355 - Penha  
São Paulo - SP - Brasil  
CEP 03649-040

tel: 11 2958 0700  
fax: 11 2958 0707

[www.waiser.com.br](http://www.waiser.com.br)  
[info@waiser.com.br](mailto:info@waiser.com.br)

Distribuidor Oficial

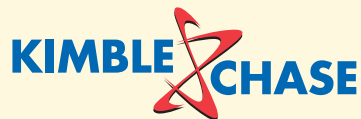

Your Source for Kimble,  
Kontes and Chase Brands



SOLUÇÕES DE  
CONFIABILIDADE

